

DIMENSIONI D'INGOMBRO - OVERALL DIMENSIONS

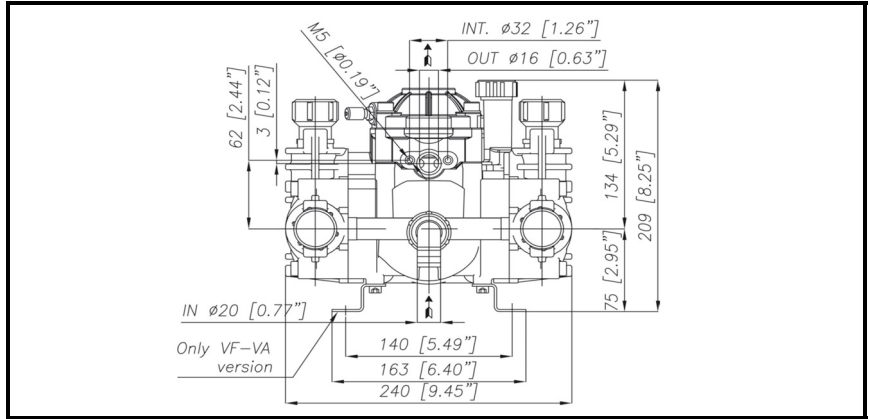

ALBERO POMPA - PUMP SHAFT

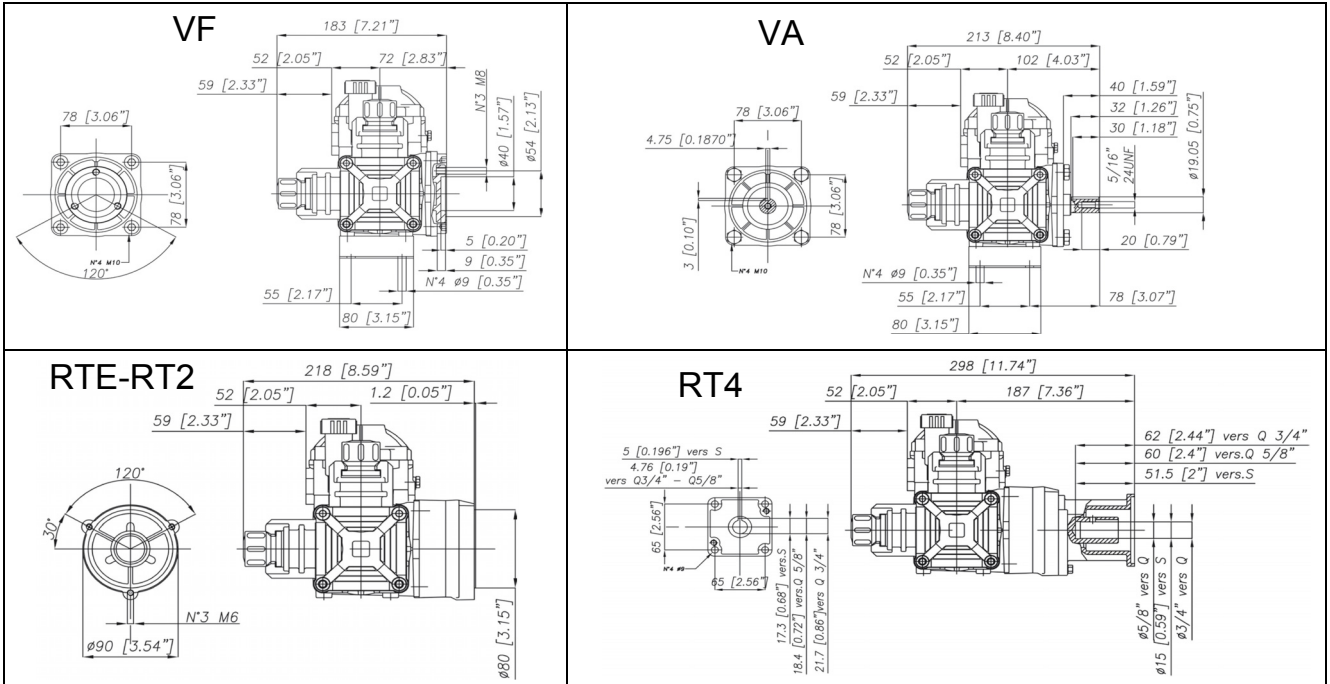

COPPIA DI SERRAGGIO - TORQUE CHART

CODICE - CODE	Q.TY	POS	N.m	Lbr.ft
86.2900.00.2	8	7	10	7,4
03.0021.97.3	2	12	5	3,7
86.1605.00.2	1	17	5	3,7
86.2945.00.2	2	21	10	7,4
86.2951.00.2	2	24	10	7,4
86.2059.00.2	2	29	10	7,4
86.3185.00.2	4	35	40	29,5
86.2458.00.2	2	53	10	7,4
86.3500.00.2	4	64	40	29,5
83.8012.00.2	3	94	10	7,4
81.4545.00.2	3	96	10	7,4
86.2566.00.2	4	99	22	16,2
86.2555.00.2				
83.8060.00.2	3	103	10	7,4
86.2059.00.2	4	108	10	7,4

Tolleranza di serraggio - Tolerance on torque value: 0/-10%

INFORMAZIONI UTILI
USEFUL INFORMATION

LUBRIFICANTE - LUBRICANT:

POMPA - PUMP:
OLIO MOTORE O SEMIDRAULICO SAE 30
MOTOR OIL OR SEMI-HYDRAULIC OIL SAE 30

RIDUTTORE - GEARBOX:
OLIO MOTORE O SEMIDRAULICO SAE 75-W90
MOTOR OIL OR SEMI-HYDRAULIC OIL SAE 75-W90

**PRESSIONE ACCUMULATORE
ACCUMULATOR PRESSURE**

PRESSIONE DI LAVORO - OPERATING PRESSURE	2 + 5	5 + 10	10 + 20	20 + 50
ACCUMULATORE ACCUMULATOR	2	2 + 5	5 + 7	6 + 8

KIT MEMBRANE - DIAPHRAGMS KIT

KIT	94.9871.97.3	BUNA - N			94.9910.97.3	VITON														
		1	18	10 15		1	18	10 15	4 6											
POSIZIONE ESPLOSO POSITION NUMBER																				
QUANTITA' NEL KIT QUANTITIES INCLUDED		2	1	4		2	2	4	4											

KIT POMPA/KIT VALVOLE - PUMP KIT/VALVES KIT

KIT	94.9879.97.3	KIT POMPA PUMP KIT								94.9888.97.3	KIT VALVOLE VALVE KIT									
		22	90	10 15	41 51	57	6 4	15 15	2		5									
POSIZIONE ESPLOSO POSITION NUMBER																				
QUANTITA' NEL KIT QUANTITIES INCLUDED		1	1	4	1	1	4	1	1		4	4								

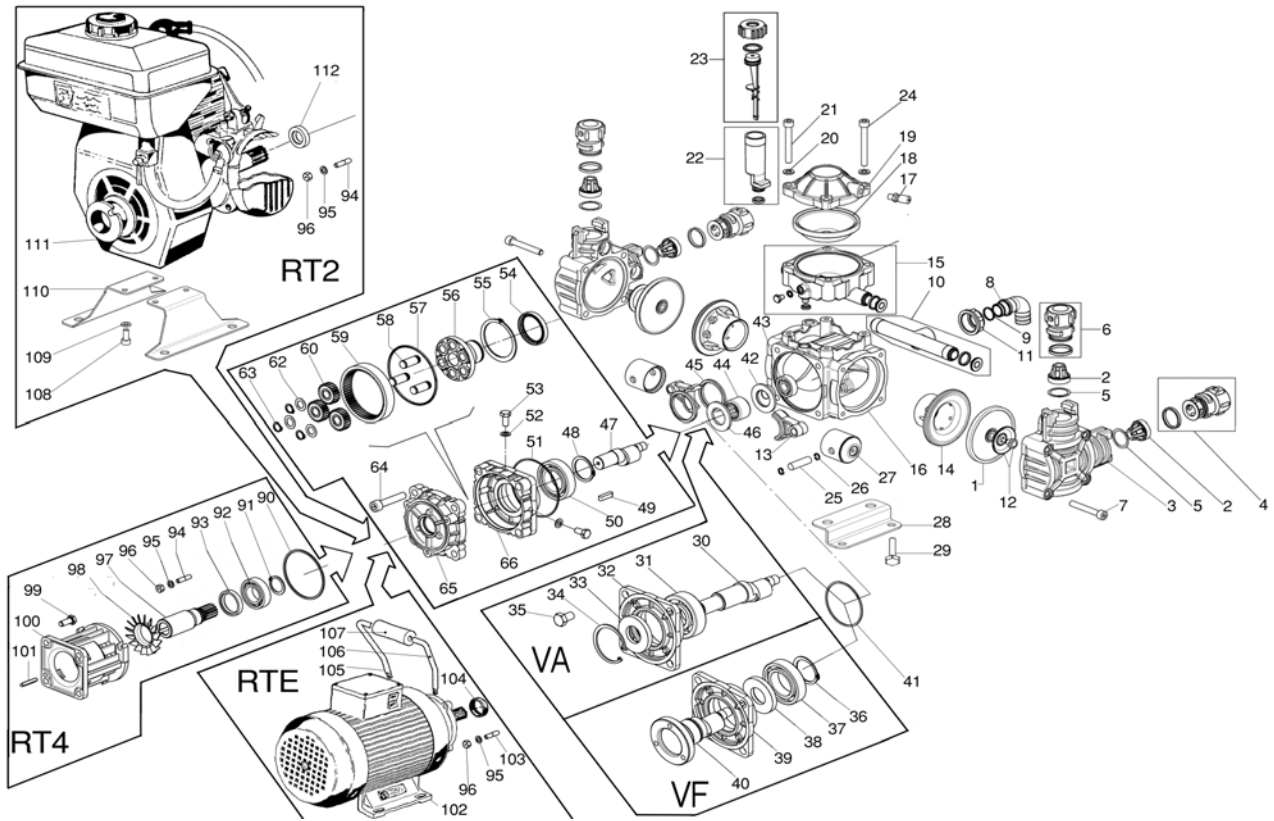

POS.	CODICE PART NO. REF.	DENOMINAZIONE - DESCRIPTION - DESCRIPTION	Q.TY	POS.	CODICE PART NO. REF.	DENOMINAZIONE - DESCRIPTION - DESCRIPTION	Q.TY
1	94.0040.31.2	PISTON DIAPHRAGM	2	48	80.1264.00.2	SNAP RING	1
1	94.0040.33.2	VITON PISTON DIAPHRAGM (OPTIONAL)	2	49	80.6473.00.2	TAB 6x6x25	1
2	94.9828.97.3	VALVE ASSY	4	50	81.2837.00.2	BEARING 35X62X14	1
3	94.0302.32.2	PUMP HEAD	2	51	80.3080.90.2	O-RING 1,78x82,27	1
4	94.9869.97.3	KIT INLET CAP	2	52	84.3642.90.2	Copper WASHER	2
5	82.4154.50.2	GASKET	4	53	86.2458.00.2	SCREW M8X12 UNI5739	2
6	94.9878.97.3	KIT OUTLET CAP	2	54	80.2178.00.2	OIL SEAL D.40X52X7	1
7	86.2900.00.2	SCREW TCEI M8x55	8	55	80.1378.00.2	SNAP RING rt2	1
8	84.0521.00.2	SUCTION CONNECTOR DIA.20-0,78"	1	55	80.1379.00.2	SNAP RING RT4	1
9	80.3060.00.2	O-RING 1.78x12.42	1	56	94.0312.09.2	GERS HOLDER HUB	1
10	94.9868.97.3	KIT INLET MANIFOLD	1	57	80.3210.67.2	O-RING 2.62x88.57	1
11	92.0042.10.2	WING NUT G.3/4	1	58	94.0315.49.2	GEAR PIN	1
12	03.0021.97.3	KIT DIAPHRAGM WASHER/SCREW AISI 316	2	59	94.0325.19.2	RING GEAR	3
13	94.0008.09.2	CONROD	2	60	94.0323.19.2	GEAR Z=24 RT4	3
14	94.0007.01.2	PISTON SLEEVE	2	60	94.0324.19.2	GEAR Z=26 RT2	3
15	94.9867.97.3	KIT DAMPER BODY	1	62	84.3880.00.2	WASHER D.12x18	3
16	94.0301.09.2	CRANKCASE	1	63	80.1081.00.2	SNAP RING DIA.12	3
17	86.1605.00.2	AIR VALVE	1	64	86.3500.00.2	SCREW TCEI M10X50 UNI5931	4
18	94.0041.31.2	DAMPER DIAPHRAGM	1	65	94.0311.09.2	GEAR BOX	1
18	94.0041.33.2	VITON DAMPER DIAPHRAGM (OPT.)	1	66	94.0310.09.2	BEARING HOUSING	1
19	94.0003.09.2	DAMPER COVER	1	90	80.3210.64.2	O-RING 2.62x75.87	1
20	84.3685.00.2	WASHER DIA.8,4x15x1,5	4	91	80.1185.00.2	RING DIA.25	1
21	86.2945.00.2	SCREW TCEI M 8X60 UNI5931	2	92	81.2700.00.2	BEARING 25X47X12	1
22	94.9866.97.3	KIT OIL FILLER	1	93	80.2117.00.2	OIL SEAL D.30X40X7	1
23	94.9855.97.3	KIT ROP OIL INDICATOR	1	94	83.8012.00.2	STUD M6X18 UNI5911 (RT4)	3
24	86.2951.00.2	SCREW TCEI M8X65 UNI5931	2	95	84.3585.00.2	WASHER DIA.6 UNI6592	3
25	85.2004.00.2	PISTON PIN	2	96	81.4545.00.2	NUT M6 UNI5587	3
26	80.0003.00.2	SNAP RING DIA.10	4	97	94.0327.42.2	PINION Z=15 20 RT4-3/4"	1
27	94.0017.08.2	PISTON POLY 2020	2	97	94.0333.42.2	PINION Z=15 20 RT4-D.15	1
28	94.0099.61.2	MOUNTING RAIL	2	97	94.0334.42.2	PINION Z=15 20 RT4-5/8"	1
29	86.2059.00.2	SCREW TE M6X14 UNI 5739	4	98	94.0353.63.2	FAN (OPTIONAL)	1
30	94.0323.26.2	CRANKSHAFT 3/4" (VA)	1	99	86.2566.00.2	SCREW TE 5/16"-24UNF (D.3/4")	4
31	81.2725.00.2	BEARING 25X62X17	1	99	86.2555.00.2	SCREW TE M8x20 UNI 5739 (D.15 D.5/8)	4
32	94.0336.09.2	BEARING HOUSING	1	100	94.0330.09.2	MOTOR FLANGE	1
33	80.2099.90.2	OIL SEAL 25X52X7 (VA)	1	101	80.6436.00.2	TAB 4,75X5X30 (D.3/4"D.5/8")	1
34	80.1369.00.2	RING D.52 PER FORO (VA)	1	101	80.6445.00.2	TAB 5x5x30 (D.15)	1
35	86.3185.00.2	SCREW TE M10X16 UNI5739	4	102	83.2061.15.2	SPECIAL ELECTRIC MOTOR 220V HP1,5	1
36	80.1264.00.2	RING D.35 PER ALBERO (VF)	1	102	83.2066.00.2	ELECTRIC MOTOR 380V HP1,25	1
37	81.2837.00.2	BEARING 35X62X14	1	103	83.8060.00.2	STUD M6X25 UNI5911 (RTE)	3
38	80.2178.10.2	OIL SEAL 40X52X7 (VF)	1	104	80.2092.00.2	OIL SEAL	1
39	94.0326.09.2	BEARING HOUSING (VF)	1	105	31.1324.61.2	LEFT HALF HANDLE	1
40	94.0335.26.2	CRANCKSHAFT (VF)	1	106	31.1325.61.2	RIGHT HALF HANDLE	1
41	80.3080.90.2	O-RING D.1.78x82.27	1	107	82.8410.00.2	KNOB	1
42	94.0026.32.2	SPACER	1	108	86.2059.00.2	SCREW TE M6X14 UNI 5739	4
43	81.2522.00.2	BEARING 12X32X10	1	109	84.3585.00.2	WASHER D6 UNI 6592	4
44	81.2688.00.2	BEARING 25X32X20	1	110	31.1168.75.2	ENGINE SUPPORT CM46	2
45	94.0047.76.2	NROD RING	2	111	83.4260.00.2	ENGINE 2T CM 46 (Z 9)	1
46	94.0027.32.2	ACER	1	111	83.2100.50.2	ENGINE 2T OLEO MAC S50 (Z 9)	1
47	94.0321.26.2	CRANKSHAFT	1	112	80.2039.00.2	OIL SEAL D15x30x7	1